

BOOMERANG series

27 ... 30 MHz Tunable Balcony Antennas

WARNING

INSTALLATION OF THIS PRODUCT NEAR POWER LINES IS DANGEROUS. FOR YOUR SAFETY AND BEFORE YOU BEGIN INSTALLATION, READ THE SEPARATE SAFETY INFORMATION SHEET.

SPECIFICATIONS

Electrical Data		
Model	BOOMERANG A	BOOMERANG W
Type	1/4 λ Ground Plane Boomerang	
Frequency Range	27 ... 30 MHz	
Impedance	50 Ω	
Radiation (H-plane)	360° Omnidirectional	
Polarization	Linear Vertical	
Gain	0 dBd - 2.15 dBi	
Bandwidth @ SWR \leq 2	1200 KHz	700 KHz
SWR @ res. freq.	\leq 1.2	
Max Power	200 Watts (CW) continuous 600 Watts (CW) short time	150 Watts (CW) continuous 450 Watts (CW) short time
Feed system / position	Direct / Centre	
Connector	UHF-female	
Mechanical Data		
Materials	Aluminium, Fiberglass, Steel, Copper, Nylon	Fiberglass, Steel, Copper, Nylon
Wind Load @ 150 km/h	52 N	45 N
Wind Resistance	140 Km/h	
Wind Surface	0.041 m ²	0.035 m ²
Height (approx.)	3900 mm	3500 mm
Radiator / Radial lenght	2750 mm / 1300 mm	1330 mm / 1250 mm
Weight (approx.)	880 gr	800 gr
Mounting Mast	With bracket supplied	

ISTRUZIONI DI TARATURA

1. Montare l'antenna:

Boomerang A: stilo $L=2750$ mm, radiale a 125° circa

Boomerang W: radiale a 170° circa.

2. Verificare la taratura dell'antenna utilizzando un ROS-metro. Se non tarata per il canale di utilizzo tagliare il radiale 5 mm alla volta fino a centratura avvenuta.

3. Per la regolazione fine dell'SWR modificare l'angolo di inclinazione del radiale fino a ottenere il miglior adattamento. Eventualmente modificare la lunghezza dello stilo verticale e ripetere la procedura dal punto 2.

TUNING INSTRUCTION

1. Install your antenna by following the standard instruction:

Boomerang A: Radiator $L=2750$ mm, Radial at approx 125°

Boomerang W: Radial at approx 170°

2. Check the antenna tuning by using a SWR-meter. If it's not tuned on the right channel, you can slightly cut the radial (not more than 5mm per cut) until you get the center band tuning.

3. For the fine tuning of the SWR you can act on the base radial by modifying the inclination angle up to get the best resonance. If it's not enough you have to act on the main radiator following the procedure of point 2.

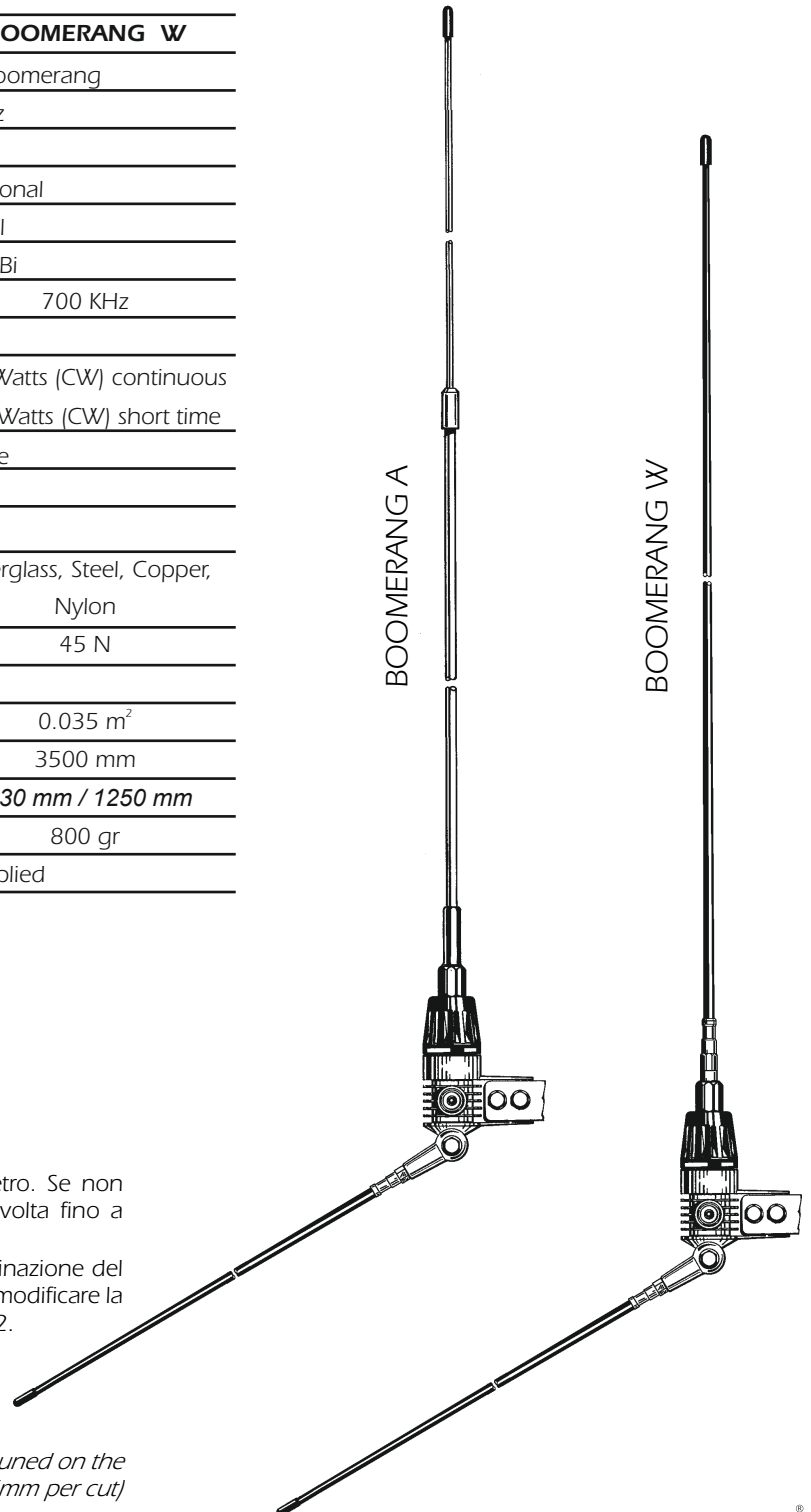

Parts List		
Pos	Q.ty	Description
1	1	Boomerang A: PVC cap for \varnothing 5 mm aluminium bar
2	1	Boomerang A: \varnothing 5x1400mm aluminium bar (top section)
3	1	Boomerang A: 2mm hexagonal key
4	1	Boomerang A: M4x4 hexagon socket set screws cup point
5	1	Boomerang A: Aluminium tube with joint (bottom section)
6	1	Boomerang W: fiberglass main radiator
7	1	mounting base with connector
8	1	fiberglass radial
9	1	Boomerang A: PVC cap for fiberglass radial
	2	Boomerang W: PVC caps for fiberglass radial and main radiator
10	1	25x200mm steel bracket
11	4	M6 washers
12	4	M6 spring lock washers
13	3	M6x12 hexagon socket head screws
14	1	M6x160 mm U-bolt
15	1	30x65mm steel bracket
16	2	M6 hexagonal nuts
17	1	zinc plated washer

Mounting needed tools:	
n. 1	tape rules (meter)
n. 1	10 mm open key
n. 1	16 mm open key

MOUNTING INSTRUCTIONS

